



Specialist for Pumping Technology



SM / SMI

**Heavy Duty, Axial Split Casing, Multi-Stage,
Between Bearings, Horizontal Centrifugal Pipeline Pump,
API 610 latest Edition**

SM / SMI

Heavy Duty, Axial Split Casing, Multi-Stage, Between Bearings, Horizontal Centrifugal Pipeline Pump, API 610 latest Edition

+75 years developing the pumping technology that drives progress

Ruhrpumpen is an innovative and efficient pump technology company that offers highly engineered, custom made solutions for oil & gas, chemical processing, power generation, industrial applications and water.

Implementation of cutting-edge technology and world-class engineering, combined with our unique vertically integrated structure, allows Ruhrpumpen to design complex technical solutions, creating the most robust and powerful pump systems in the marketplace.

Our broad product line complies with the most demanding quality standards and industry specifications such as **American Petroleum Institute (API)**, **American National Standards Institute (ANSI)**, **Underwriter's Laboratories (UL)**, **Factory Mutual (FM)**, **National Fire Protection Association (NFPA)**, **ISO** and **Hydraulic Institute**.

Products Include:

- Single stage overhung pumps
- Vertical in-line pumps
- Single and multi-stage between bearing pumps
- Multi-stage vertical pumps
- Reciprocating plunger pumps
- Sealless magnetic drive pumps
- Fire protection systems
- Pitot tube pumps
- Hydraulic decoking systems
- Horizontal pumping systems



Ruhrpumpen is your single source supplier

- Original Equipment
- Spare parts
- Installation and startup support
- Repair and maintenance
- Engineering, training and consulting
- Reverse engineering

Benefits of our pumps

- Proven reliability
- High efficiency designs ensure lowest operating cost
- Robust design allows for long system life with minimal maintenance
- Optimized total cost of ownership

SM / SMI Pumps

The Ruhrpumpen SM / SMI are heavy duty, horizontal volute, multi-stage, centrifugal pumps of the BB3 configuration according to API 610, latest edition.

SM / SMI pumps with axial split casing are robust and reliable. Hydraulic balance is obtained by arranging the impellers in opposed groups. They are designed to withstand medium up to high pressure ranges. SM / SMI pumps are easy to inspect and maintain, due to the volute design which allows direct access to the rotor. The lower casing half will remain on the baseplate connected to the pipeworks during inspection and dismantling. This guarantees free access to the rotating assembly.

They are the number one choice for applications involving high-flow and high pressure. They are mainly used as crude oil, water / water injection oil product pipeline pumps in Oilfields and Terminals in single & parallel operation.

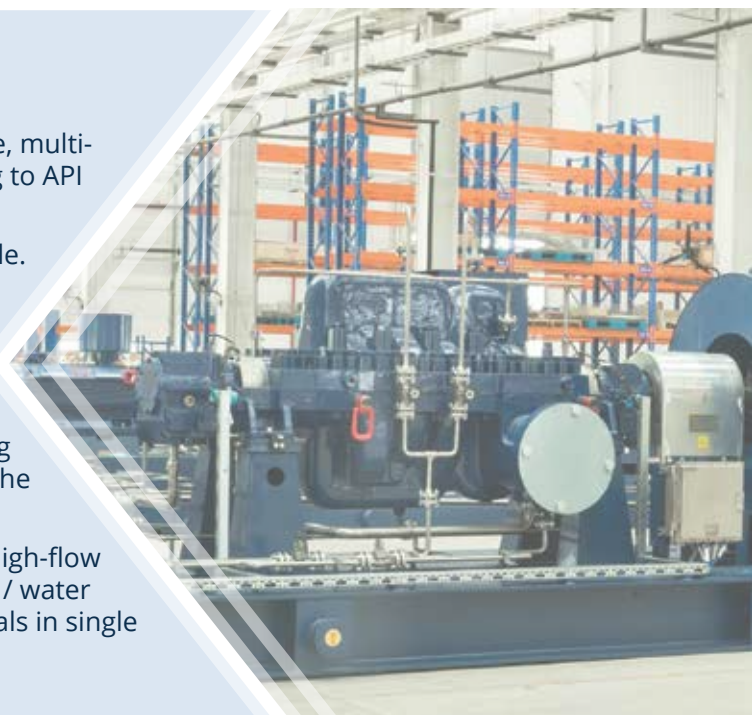

The SM / SMI Pump Complementary Design

The SM / SMI is available in numerous sizes and options. The suction and discharge nozzles have a side-side orientation, axially offset in the lower half casing.

The symmetrical execution of the upper and lower casing halves and a near centerline support ensures continuous operation even at high temperatures. The SM / SMI pumps have high efficiencies and low sound pressure levels due to extensive research and testing.

For low NPSHA applications a double suction first stage impeller is also available for some models.

The bottom half casing can be fitted with an optional, flanged stuffing box pressure balance line, which allows both the DE and NDE stuffing boxes to be at the same pressures, where this feature is required.

All pressurized casing parts are hydrostatically tested at 1.5 times the maximum allowable working pressure.



Performance Range

SELECTION CHART SM/SMI

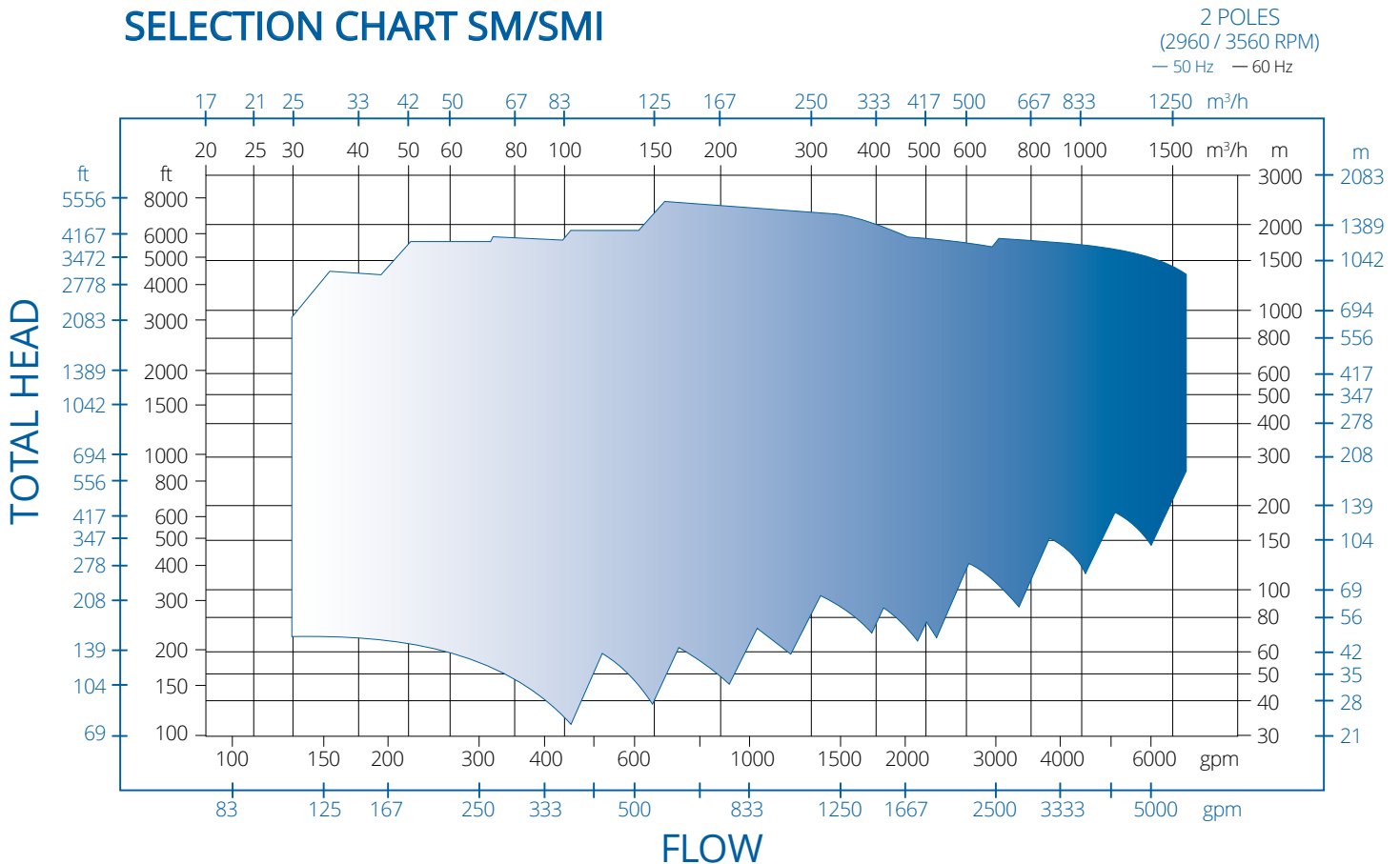

SM / SMI

Heavy Duty, Axial Split Casing, Multi-Stage, Between Bearings, Horizontal Centrifugal Pipeline Pump, API 610 latest Edition

Characteristics

- 1 AXIAL SPLIT CASING**
Full design pressure, double volute construction, hydraulically balanced, near centerline mounted. A balancing line equalizes the pressure in both seal chambers.
- 2 PRECISION CAST**
Closed Impellers, dynamically balanced, individually secured against movements in either direction.
- 3 REPLACEABLE WEAR RINGS**
Impeller Wear Rings, shrink fitted and secured by axial locking screws.
- 4 LARGE SHAFT DIAMETER**
Ample sized to satisfy stringent shaft dynamic and power transmission requirements, shaft ends tapered.
- 5 SEAL CHAMBERS**
Are in compliance with API 682 ready to accommodate single as well as tandem and double mechanical cartridge seals. Throttle bushing sized.
- 6 CENTER BUSHING**
Sized to minimize internal flow between high - and low pressure side and to support rotordynamics.
- 7 BEARING HOUSINGS**
With air cooling, finned surface and standard ringoil lubrication. Pure or purge oil mist lubrication available on request. Bearing housing covers are equipped with INPRO® bearing isolators. Roller bearing in the drive end and an angular contact bearing in the non-drive end as standard (AntiFriction Bearings). Sleeve/Roller-Anti-Friction and Sleeve/Tilting Pad configurations are optional.
- 8 IMPELLERS ARRANGED IN OPPOSED GROUPS**
Pumps available up to 14 stages.
- 9 SPECIAL IMPELLER DESIGN**
For low NPSHA applications, a double suction impeller for the first stage is available for most of the pump sizes.

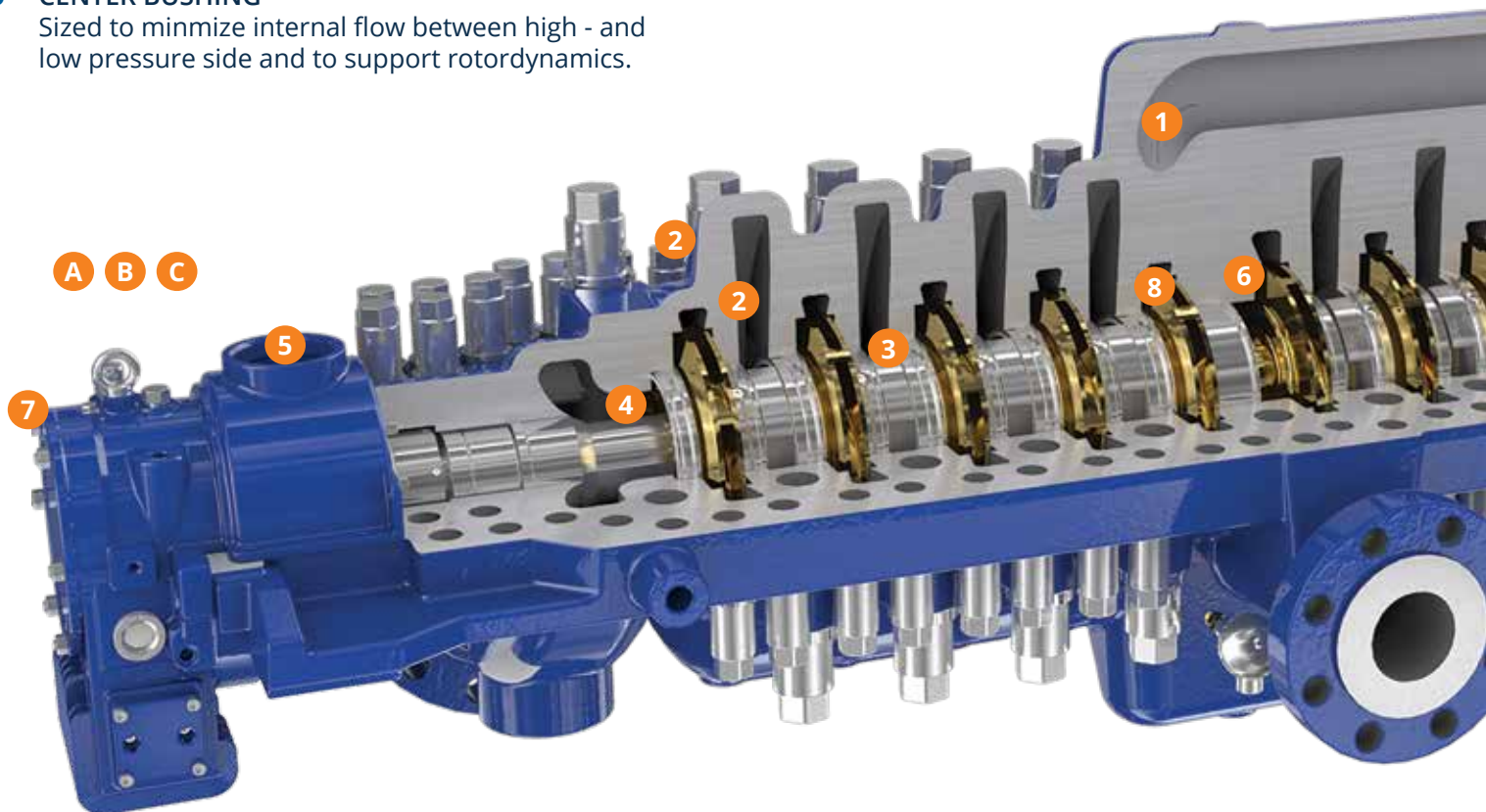

SPECIAL BEARING DESIGNS

Other bearing designs are available in order to suit all customer needs:

- a. Heavy duty Axial Thrust Bearing configuration specially developed for pipeline services.
- b. Tilting Pad Thrust Bearing design with forced feed lubrication is available for high axial loads.
- c. Radial Sleeve Bearings for higher radial loads on DE and NDE are available with ring-oil lubrication or optional with forced feed lubrication.



DESCRIPTION

- Multi-stage horizontal centrifugal pump.
- Axially split casing.
- Centerline mounted.
- Side-side suction and discharge nozzles.
- Roller bearings with oil ring bearing lubrication. Optional sleeve bearings.
- Easy to inspect and maintain.
- Weight optimization.
- Double row bolting for upper and lower part for high-pressure design. (SM line)
- Option: light interference fit for impellers on stepped shaft.
- Shaft key for torque transmission or hydraulic fitted hub.
- API 610 latest edition (API pump type BB3).

BROAD APPLICATION RANGE

- Oilfields and Terminals
- Crude Oil and Oil Product Pipelines (single & parallel operation)
- Water Pipelines
- Boiler feed
- Fluid Injection
- Process charge
- De-Scaling
- Mine dewatering
- Reverse Osmosis
- Power recovery
- High Pressure Services

PERFORMANCE DATA

| | | |
|-------------|-------------------------------|-------------------------------|
| Capacity | up to 2,000 m ³ /h | 8,800 gpm |
| Head | up to 1,600 m | 5,330 ft |
| Pressure | up to 276 bar | 4,000 psi |
| Temperature | -80°C to 200°C | -110°F to 3°F |
| Speed | 2950 min ⁻¹ (50Hz) | 3550 min ⁻¹ (60Hz) |

Notes:

For pump operations outside this range, please contact a Ruhrpumpen Representative.

SM / SMI

Heavy Duty, Axial Split Casing, Multi-Stage, Between Bearings, Horizontal Centrifugal Pipeline Pump, API 610 latest Edition

Other Characteristics

Bearing Cooling

Bearings are fan cooled as standard, but can also be water or product cooled.

The SM / SMI pump can be constructed on a skid

Pump skids can be specifically designed to meet customer specifications. The skids can include such items as Seal Systems, Cooling Piping Plans, Controllers, Monitoring Instruments, Seals, Lubrication Systems, and other instrumentation upon request. The base plates can also be customized to meet specific customer requirements.

Pump Rotation

Standard rotation is Counter Clockwise viewed from coupling end; Clockwise rotation is also available.

Suction and Discharge Nozzle

Side/side nozzle configuration. The discharge and suction nozzles are located in the bottom part of the pump casing. Standard are ANSI flanges with the required rating, but flanges according to other standards (DIN, JIS,...) are also possible on request.

Ruhrpumpen Continuous Improvement

Ruhrpumpen uses state-of-the-art computer fluid dynamics, 3-D-modeling and finite-element-analysis software for product improvement. Experienced engineers use these tools to improve the product lines, but also to design the optimum solution for customer-specific applications. All pressurized casing parts are hydrostatically tested at 1.5 times the maximum allowable working pressure.



Fig 1. Result of FEA of packing under a test pressure of 276 bar. No leaking was found.

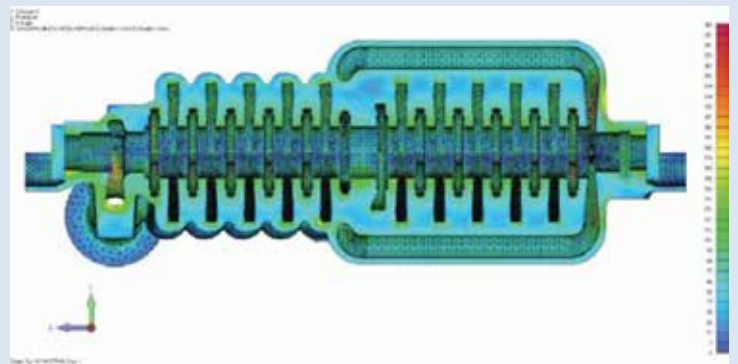
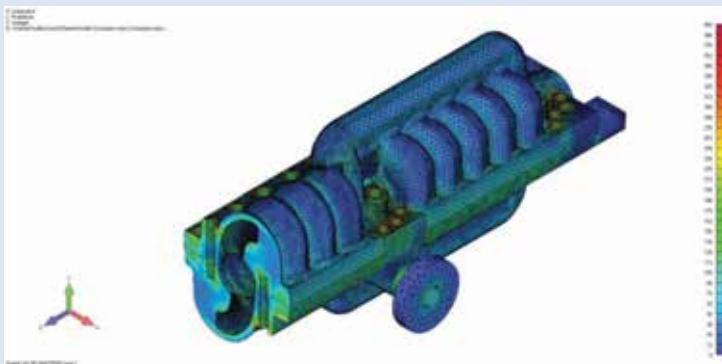

Fig 2 and 3. Result of FEA of “von Mises stress” under a test pressure of 276 bar.

Other Ruhrpumpen Products

Horizontally Split Multi-Stage Diffuser Casing



Heavy-duty process pump, two and four stage, double volute, side-side nozzle, enclosed impeller.

High Pressure Applications such as Boiler Feed, Petrochemical, Chemical Industrial and Power Plants.



Horizontal Multi-Stage Barrel Pump

Heavy-duty, high pressure, radially split, centerline mounted, diffuser casing, single / double suction, enclosed impellers, top-top nozzles. Standard construction materials according to API latest edition (type BB5).

Fluid Injection, Oil Fields & Terminals, Water, Crude Oil & Oil Products Pipelines and Power Plants.

Single Stage Horizontal Pump



Overhung, radially split, flanged connections, enclosed impeller, mechanical seal. Standard construction materials according to API latest edition (type OH2).

Municipal, General Industry, Irrigation, Fire Service and Pressure Equipments.



Vertical Barrel Pump

Low NPSH "Shockless Entry" first stage impeller (single or double suction), Single or multi-stage. Standard construction materials according to API 610 latest edition (type VS6).

Condensate, Power Plants, Municipal, Hydrocarbons, Pipeline and Refineries.











+75 years creating the pumping technology that moves our world

Ruhrpumpen is an innovative and efficient pump technology company that offers highly-engineered and standard pumping solutions for the oil & gas, power generation, industrial, water and chemical markets. We offer a broad range of centrifugal and reciprocating pumps that meet and exceed the requirements of the most demanding quality specifications and industry standards such as API, ANSI, UL, FM, ISO and Hydraulic Institute.



Ruhrpumpen Plants

-  ARGENTINA, Buenos Aires
-  BRAZIL, Rio de Janeiro
-  CHINA, Changzhou
-  EGYPT, Suez
-  GERMANY, Witten
-  INDIA, Chennai
-  MEXICO, Monterrey
-  UK, Lancing
-  USA, Tulsa

-  Manufacturing plant & service center
-  Service center